

SANTON

PowerPack™

Instantaneous Water Heater

Instantaneous Water Heating



PowerPack

Instantaneous Water Heater

PowerPack is a compact instantaneous water heater. It can supply a shower outlet and/or spray tap, provided only one outlet is used at a time. PowerPack is ideally suited to supplying heated water to a remote area, such as a garage or cloakroom. It can be concealed from view and thus be protected from vandalism.



- 7kW, 9kW and 12kW* models.
- Ideal for supplying hot water for bedsits, student accommodation and to remote areas.
- White moulded vandal resistant ABS casing.
- High temperature cut-out for safety.

*Available Quarter One 2010.

PowerPack

Technical Specification

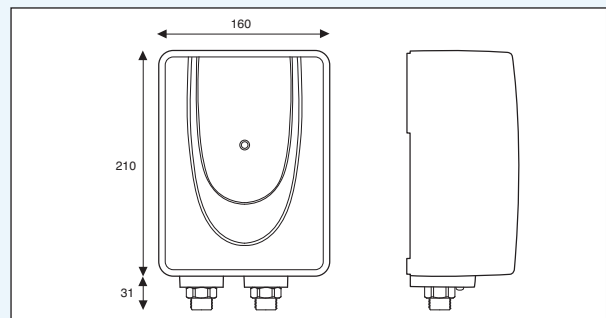

Ordering Guide

Model	Product Code	Rating
PowerPack	94:050:211	7kW @ 240V single phase AC
PowerPack	94:050:212	9kW @ 240V single phase AC
PowerPack	94:050:213	12kW* @ 240V single phase AC

*Available Quarter One 2010.

Controls

A reed switch activates the unit when the water flows. A pre-set safety cut-out set at 88°C (190°F) prevents overheating should abnormal conditions arise.

Casing

Moulded from white ABS.

Inner Container

Glass reinforced plastic cylinder, complete with inlet/outlet connections and element. A drain plug is fitted to drain the container to prevent freezing if left in winter.

Fittings

A pressure relief valve set to relieve at 10 bar is provided together with a tee-piece which must be fitted on the cold water inlet. This valve MUST be connected to waste (drain) via a tundish and the drain pipe should fall continuously and be of 22mm bore discharging in a safe visible manner. The pipe must not be reduced in bore or blocked under any circumstances and it should be protected from frost.

Pressure Range

Min: 1 bar.
Max: 7 bar.

Connections

1/2" BSP inlet and outlet.

Approvals

BEAB and kiwa approved.
CE marked.

Guarantee

Two years.
Full details are contained within the installation instructions supplied with each unit.



SANTON

Santon, Hurricane Way,
Norwich, Norfolk, NR6 6EA

Specification

T: 01603 420128 F: 01603 420229 E: specifier@santon.co.uk

After Sales Service

T: 0844 871 1530 F: 0844 871 1528

Literature hotline

T: 01603 420127

The pace of product development is such that we reserve the right to change product specifications without notice. We do, however, strive to ensure that all information in this catalogue is accurate at the time of going to publication.



This product is printed on 50% post consumer recycled paper. That is paper that has been previously used eg. newspapers and magazines. This product is printed using vegetable based inks which are non toxic. Please recycle this product once you have finished with it.